

R-IN32M3 Module (RY9012A0)

R19DS0109ED0201

Rev.2.01

Jun 14, 2021

Industrial Ethernet Module

Description

The Renesas R-IN32M3 Module is currently available and ready for use. It is certified as a dual-port Ethernet module solution for the PROFINET, EtherNet/IP™, and EtherCAT® real-time protocols, and includes a 2-port Ethernet switch and a third internal port for bus and ring network topologies. Example applications are available.

The R-IN32M3 Module includes a Renesas microcontroller running a protocol library which supports various kinds of real-time industrial Ethernet communication protocols. A well-documented generic application programming interface (API) allows for simple access to the protocol library by an application processor in order to exchange real-time network data with a user application via a lean SPI module interface.

The generic API is an abstraction platform for real-time communications offering scalable multi-protocol solutions such as PROFINET RT, EtherNet/IP, and EtherCAT. The external application processor has full control of the protocol stacks running on the module's CPU without interfering with the modules' real-time communications or wasting the CPU performance of the host processor.

The implementations of the currently available industrial Ethernet protocols, PROFINET RT, EtherNet/IP, and EtherCAT, comply with the latest specification releases. An extensive tool chain, covering an evaluation board (module and application processor), API source code, and host application examples including extensive documentation, eases integration into your target application environment. All this enables users to set up a lean and independent connection to existing or new applications, products, and networks while accelerating times to market.

Functions

- A complete dual Ethernet interface based on the IEEE 802.3 standard, including transformers and PHY modules
- Embedded 2-port Ethernet switch for bus and ring network topologies
- High-speed SPI interface and power pins for connecting the module to a host CPU
- Integrated processor to handle the real-time industrial Ethernet protocols

Product Features

- Support for the PROFINET RT, EtherNet/IP, and EtherCAT real-time communication standards
- Ethernet ports supporting 10 Mbits per second and 100 Mbits per second with auto negotiation
- Device configuration via the Management Tool (Industrial Communication Explorer from the company "port industrial automation GmbH") and API through an application controller
- Comprehensive tool support and application examples in the form of source code for the Renesas RA, RX and Synergy

Industrial Ethernet Protocol Features

R-IN32M3 Module supports the following features in a condition of firmware Ver2.0.0 or later.

PROFINET

- PROFINET IO Conformance Class B
- Up to 1 ms Cyclic Communication
- Max. read/write 768 Byte process data
- Supports LLDP, SNMP
- Supports web browser and http

EtherNet/IP

- Up to 1 ms Cyclic Communication
- Max. read/write 73 Byte process data
- Max. 73 Byte Explicit Message
- Supports DLR (Device Level Ring)
- Supports QoS
- Supports web browser and http

EtherCAT

- EtherCAT communication profile
 - CAN application protocol over EtherCAT (CoE)
 - Ethernet over EtherCAT (EoE)
 - File Access over EtherCAT (FoE)
- Supports Explicit Device ID
- Supports; Free-Run, Sync Manager and Distributed Clocks (DC)
- Max. TxPDO 64 Byte
- Max. RxPDO 64 Byte
- Custom device profile (like a Semi profile (5003))

Ordering Information

| Part No. | Application | Package |
|----------------------|-------------------------------|------------------------|
| RY9012A0000GZ00#001 | Dual-port Ethernet module | 30-piece tray package |
| RY9012A0000GZ00#002 | Dual-port Ethernet module | 1-piece sample package |
| YCONNECT-IT-I-RJ4501 | Solution kit for the host I/F | - |

Note: The information in this document is subject to change without notice. Before using this document, please confirm that this is the latest version.

Not all products and/or types are available in every country. Please check with our sales representative for availability and additional information.

Application Example

A typical application example is shown in the following diagram. Sensors and actuators connected to an external application processor communicate with the R-IN32M3 Module via the SPI. The module with its embedded processor handles the real-time communications protocol and is connected to the Ethernet-based network.

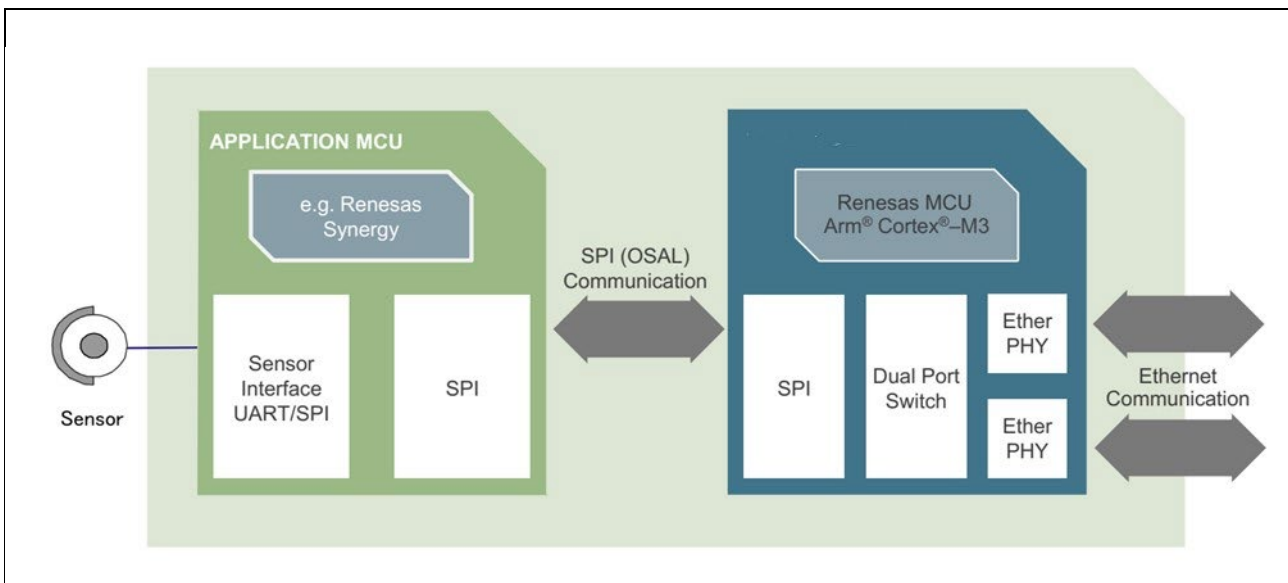

SPI Operation

The SPI of the R-IN32M3 Module is intended to interface the module to the external application processor.

For independence of the module clock from the clock of the external application processor, serial transfer through the SPI interface is in asynchronous mode and handled by the following four pins of the module.

- MOSI (master out, slave in)
- MISO (master in, slave out)
- SCLK (RSPI clock) signals
- SS (slave select)

The application controller as SPI master determines the mode of SPI communications. The SPI data format is MSB-first, and the number of bits in each transfer is 8 bits. A 128-byte transfer buffer allows the transport of multiple requests.

Communications are based on a cyclic scheme, where process data can be transmitted cyclically in response to each request from the application controller. The same transport system is used for both real-time and non-real-time communications (RPC). However, processing for this is decoupled from that for real-time communications. Thus, real-time data can be exchanged independently of calls of the API functions.

1. Pin Arrangement

The module pins consist of those for Ethernet, power supply, SPI, and synchronization. The SPI is a slave interface.

2. Pin Description

2.1 Ethernet Port

The Ethernet ports comply with IEEE 802.3 10BASE-T / 100BASE-TX, half/full duplex and have the following pin assignment as listed in Table 2.1.

Table 2.1 Ethernet Port

| Pin | Signal | I/O | Description |
|-----|----------|-----|--------------------------|
| 1 | TX+ | O | Transmit signal positive |
| 2 | TX- | O | Transmit signal negative |
| 3 | RX+ | I | Receive signal positive |
| 4 | Not used | | Drain wire |
| 5 | Not used | | Drain wire |
| 6 | RX- | I | Receive signal negative |
| 7 | Not used | | Drain wire |
| 8 | Not used | | Drain wire |

2.2 Application Interface

The module pins interface with power supply and SPI. The SPI is a slave interface.

Table 2.2 Application Interface

| Pin | Signal | I/O | Description |
|-----|--------|-----|--|
| 1 | Vcc | | 3.3V \pm 0.15V DC power supply |
| 2 | GND | | Ground |
| 3 | /SS | I | Slave select: Active low to enable the slave device |
| 4 | /RESET | I | Reset of the whole R-IN32M3 Module: Active low |
| 5 | MISO | O | Master in slave out: Data from slave to master |
| 6 | MOSI | I | Master out slave in: Data from master to slave |
| 7 | SCLK | I | Serial clock: The master provides the clock to time shifting of the data |
| 8 | SYNC0 | O | EtherCAT sync signal for distributed clocks |
| 9 | SYNC1 | O | EtherCAT sync signal for distributed clocks |

Note: Pin 8 and pin 9 EtherCAT sync signals for distributed clocks are only used for the EtherCAT protocol. They operate according to the EtherCAT specification.

3. Internal Block Diagram

3.1 Block Diagram: Hardware

Figure 3.1 shows the internal hardware blocks of the R-IN32M3 Module.

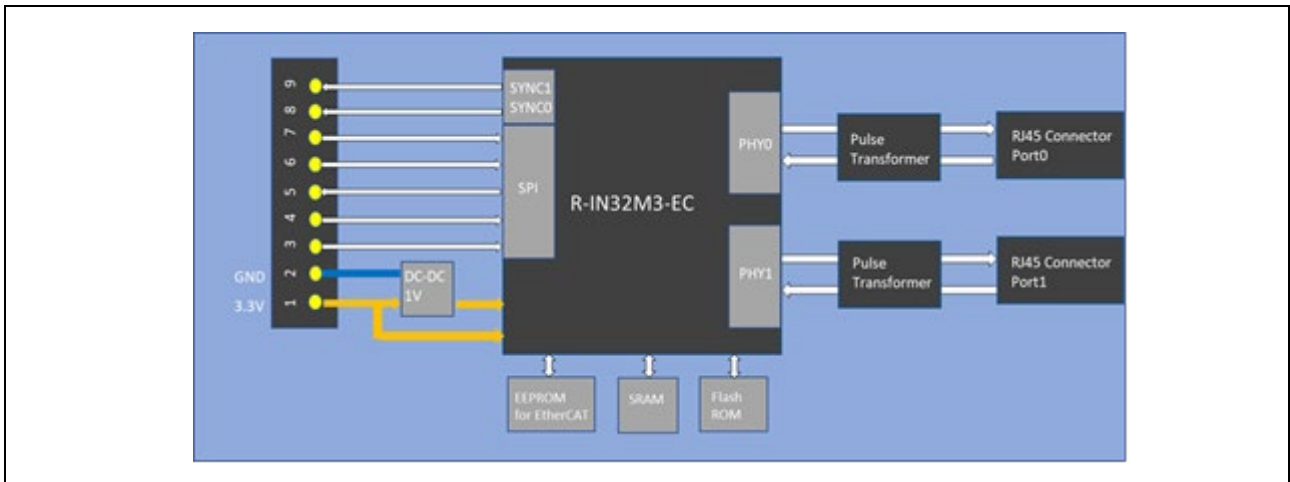

Figure 3.1 Internal Hardware Blocks of the R-IN32M3 Module

3.2 Block Diagram: Software

Figure 3.2 shows the software blocks of the R-IN32M3 Module and how they are connected with the application processor.

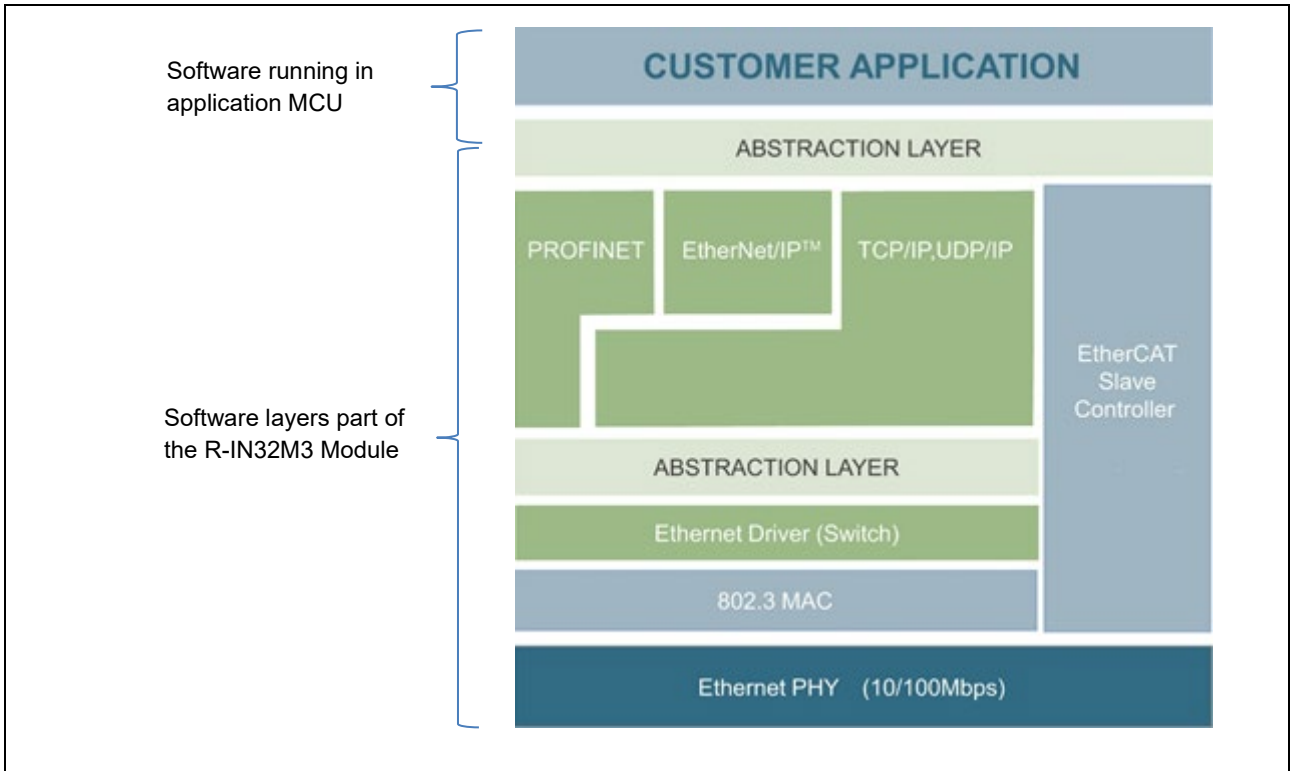

Figure 3.2 Software Blocks of the R-IN32M3 Module Solution

4. Electrical Characteristics

4.1 Absolute Maximum Ratings

Stress exceeding the maximum ratings even for short time may damage the R-IN32M3 Module. Functional operation above the recommended operating conditions is not guaranteed. Extended exposure to stress above the recommended operating conditions may affect device reliability.

Table 4.1 Absolute Maximum Ratings

| Parameter | Symbol | Rating | Unit |
|---------------------|-----------|--------------|------|
| Supply voltage | V_{CC} | -0.2 to +3.6 | V |
| I/O voltage | V_I/V_O | -0.3 to +3.6 | V |
| Output current | I_O | 15 | mA |
| Storage temperature | T_{stg} | -40 to +85 | °C |

Remark: Tests performed IEC 60512-11-4 (-40°C/125°C), IEC 60512-11-9 (125°C), IEC 60512-11-10 (-40°C), IEC 60512-11-3 (40°C /85%RH), IEC 60512-11-12

Caution: Product quality may suffer if any absolute maximum rating is even momentarily exceeded. That is, the absolute maximum ratings are rated values at which the product is on the verge of suffering physical damage, and therefore the product must be used under conditions that ensure that these ratings are not exceeded.

Remark: 3.3 V must be applied to the I/O pins only after applying the power supply voltage.

4.2 Operating Conditions

Table 4.2 Operating Conditions

| Parameter | Symbol | Min. | Typ. | Max. | Unit |
|-----------------------------|------------------|----------------|------|----------------|------|
| Power supply | V_{CC} | 3.15 | 3.3 | 3.45 | V |
| Power consumption | P | | 1.3 | 2.0 | W |
| Input voltage high | V_{IH} | 2.0 | | $V_{CC} + 0.3$ | V |
| Input voltage low | V_{IL} | -0.3 | | 0.8 | V |
| Input voltage high (/RESET) | $V_{IH_{RESET}}$ | 2.2 | | V_{CC} | V |
| Input voltage low (/RESET) | $V_{IL_{RESET}}$ | -0.2 | | 0.3 | V |
| Output voltage high | V_{OH} | $V_{CC} - 0.1$ | | | V |
| Output voltage low | V_{OL} | | | 0.1 | V |
| Output current low | I_{OL} | 6 | | | mA |
| Output current high | I_{OH} | -6 | | | mA |
| Operating temperature | T_a | -40 | | 70 | °C |

All further specifications and statements of timing assume the application of the operating conditions listed in Table 4.2.

4.3 SPI Specification

Table 4.3 SPI Specification

$V_{CC} = 3.3 \pm 0.15 \text{ V}$, $T_a = -40 \text{ to } +70^\circ\text{C}$

| Parameter | Symbol | Conditions | Min. | Max. | Unit |
|------------------------------|---------------|-----------------------|--------------------------------|------|------|
| SCLK input cycle | $t_{CSISSCK}$ | - | 60 | - | ns |
| SCLK output high level width | t_{WSKH} | - | $t_{CSIMSCK} \times 0.5 - 5.0$ | - | ns |
| SCLK output low level width | t_{WSKL} | - | $t_{CSIMSCK} \times 0.5 - 5.0$ | - | ns |
| MOSI input | t_{SSSI} | - | 10 | - | ns |
| | t_{SSSI} | - | 10 | - | ns |
| | t_{HSSI} | - | 15 | - | ns |
| | t_{HSSI} | - | 15 | - | ns |
| | t_{DSSO} | $C_L = 15 \text{ pF}$ | - | 10 | ns |
| | t_{DSSO} | | - | 10 | ns |
| | t_{HSSO} | | $t_{CSISSCK} \times 0.5 - 5.0$ | - | ns |
| | t_{HSSO} | | $t_{CSISSCK} \times 0.5 - 5.0$ | - | ns |

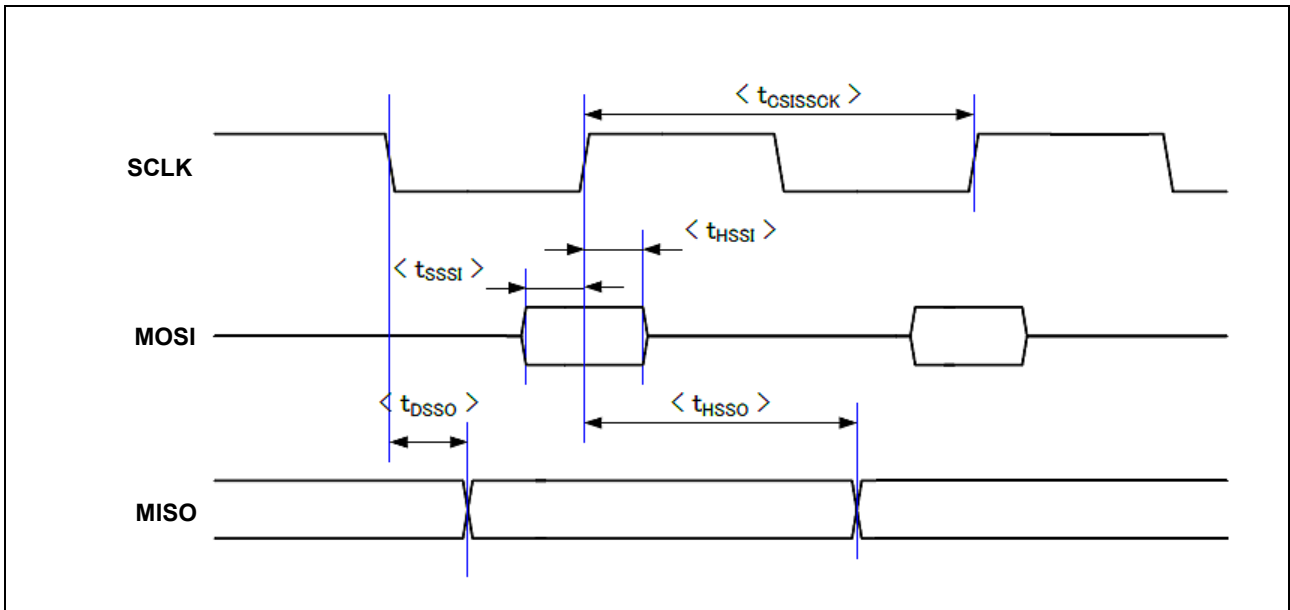

Figure 4.1 SPI Access Timing Chart

5. Applicable Standards

The R-IN32M3 Module complies with the following standards:

CE marking

- Emission EN61000-6-4
 - EN55016-2-3 Radiated emission
 - EN55022 Conducted emission
- Immunity EN61000-6-2
 - EN61000-4-2 Electrostatic Discharge immunity test
 - EN61000-4-3 Immunity to radiated radio frequencies
 - EN61000-4-4 Electrical fast transient / burst immunity test
 - EN61000-4-5 Surge immunity test
 - EN61000-4-6 Immunity to conducted disturbances, induced by radio-frequency fields

RoHS / REACH



UL

6. Package Dimensions

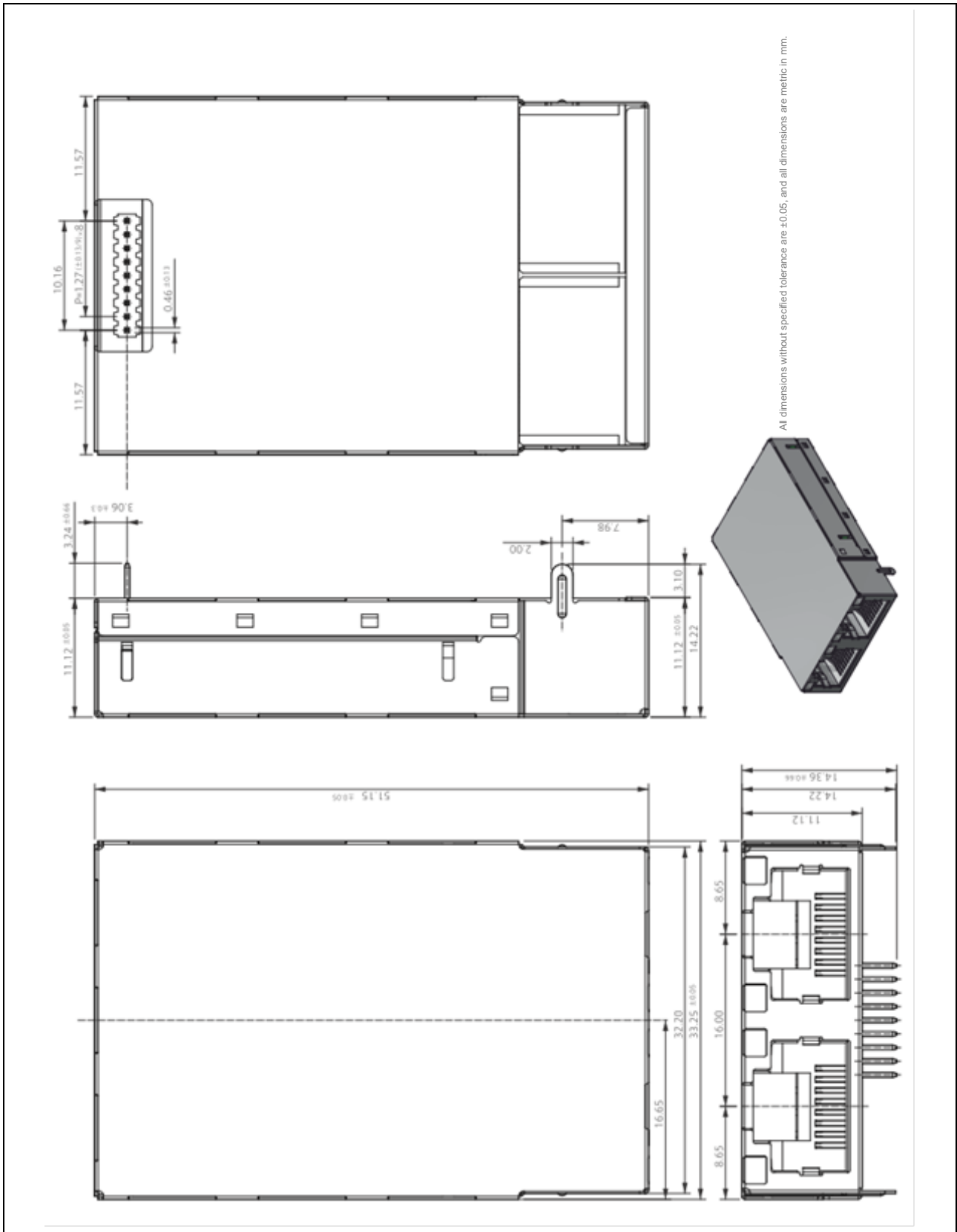

Figure 6.1 Package Dimensions

Related Products

YCONNECT-IT-I-RJ4501

The solution kit for the R-IN32M3 Module containing

- An Arduino compatible development board with the R-IN32M3 Module
- SW package including source code for an application processor to easily configure the module
- Documentation

| Revision History | | R-IN32M3 Module (RY9012A0) Datasheet | |
|------------------|--------------|--------------------------------------|---|
| Rev. | Date | Description | |
| | | Page | Summary |
| 1.00 | Aug 03, 2020 | - | First Edition issued |
| 2.00 | Nov 06, 2020 | 1 | Update to Industrial Communication Explorer |
| 2.01 | Jun 14, 2021 | 2 | Add support protocol functions |

General Precautions in the Handling of Microprocessing Unit and Microcontroller Unit Products

The following usage notes are applicable to all Microprocessing unit and Microcontroller unit products from Renesas. For detailed usage notes on the products covered by this document, refer to the relevant sections of the document as well as any technical updates that have been issued for the products.

1. Precaution against Electrostatic Discharge (ESD)

A strong electrical field, when exposed to a CMOS device, can cause destruction of the gate oxide and ultimately degrade the device operation. Steps must be taken to stop the generation of static electricity as much as possible, and quickly dissipate it when it occurs. Environmental control must be adequate. When it is dry, a humidifier should be used. This is recommended to avoid using insulators that can easily build up static electricity.

Semiconductor devices must be stored and transported in an anti-static container, static shielding bag or conductive material. All test and measurement tools including work benches and floors must be grounded. The operator must also be grounded using a wrist strap. Semiconductor devices must not be touched with bare hands. Similar precautions must be taken for printed circuit boards with mounted semiconductor devices.

2. Processing at power-on

The state of the product is undefined at the time when power is supplied. The states of internal circuits in the LSI are indeterminate and the states of register settings and pins are undefined at the time when power is supplied. In a finished product where the reset signal is applied to the external reset pin, the states of pins are not guaranteed from the time when power is supplied until the reset process is completed. In a similar way, the states of pins in a product that is reset by an on-chip power-on reset function are not guaranteed from the time when power is supplied until the power reaches the level at which resetting is specified.

3. Input of signal during power-off state

Do not input signals or an I/O pull-up power supply while the device is powered off. The current injection that results from input of such a signal or I/O pull-up power supply may cause malfunction and the abnormal current that passes in the device at this time may cause degradation of internal elements. Follow the guideline for input signal during power-off state as described in your product documentation.

4. Handling of unused pins

Handle unused pins in accordance with the directions given under handling of unused pins in the manual. The input pins of CMOS products are generally in the high-impedance state. In operation with an unused pin in the open-circuit state, extra electromagnetic noise is induced in the vicinity of the LSI, an associated shoot-through current flows internally, and malfunctions occur due to the false recognition of the pin state as an input signal become possible.

5. Clock signals

After applying a reset, only release the reset line after the operating clock signal becomes stable. When switching the clock signal during program execution, wait until the target clock signal is stabilized. When the clock signal is generated with an external resonator or from an external oscillator during a reset, ensure that the reset line is only released after full stabilization of the clock signal. Additionally, when switching to a clock signal produced with an external resonator or by an external oscillator while program execution is in progress, wait until the target clock signal is stable.

6. Voltage application waveform at input pin

Waveform distortion due to input noise or a reflected wave may cause malfunction. If the input of the CMOS device stays in the area between V_{IL} (Max.) and V_{IH} (Min.) due to noise, for example, the device may malfunction. Take care to prevent chattering noise from entering the device when the input level is fixed, and also in the transition period when the input level passes through the area between V_{IL} (Max.) and V_{IH} (Min.).

7. Prohibition of access to reserved addresses

Access to reserved addresses is prohibited. The reserved addresses are provided for possible future expansion of functions. Do not access these addresses as the correct operation of the LSI is not guaranteed.

8. Differences between products

Before changing from one product to another, for example to a product with a different part number, confirm that the change will not lead to problems. The characteristics of a microprocessing unit or microcontroller unit products in the same group but having a different part number might differ in terms of internal memory capacity, layout pattern, and other factors, which can affect the ranges of electrical characteristics, such as characteristic values, operating margins, immunity to noise, and amount of radiated noise. When changing to a product with a different part number, implement a system-evaluation test for the given product.

• Ethernet is a registered trademark of Fuji Xerox Limited.

• IEEE is a registered trademark of the Institute of Electrical and Electronics Engineers, Inc.

• EtherCAT® is registered trademark and patented technology, licensed by Beckhoff Automation GmbH, Germany.

• PROFINET is a registered trademark of PROFIBUS and PROFINET International (PI).

• EtherNet/IP is a trademark of ODVA, Inc

• Additionally all product names and service names in this document are a trademark or a registered trademark which belongs to the respective owners.

Notice

1. Descriptions of circuits, software and other related information in this document are provided only to illustrate the operation of semiconductor products and application examples. You are fully responsible for the incorporation or any other use of the circuits, software, and information in the design of your product or system. Renesas Electronics disclaims any and all liability for any losses and damages incurred by you or third parties arising from the use of these circuits, software, or information.
2. Renesas Electronics hereby expressly disclaims any warranties against and liability for infringement or any other claims involving patents, copyrights, or other intellectual property rights of third parties, by or arising from the use of Renesas Electronics products or technical information described in this document, including but not limited to, the product data, drawings, charts, programs, algorithms, and application examples.
3. No license, express, implied or otherwise, is granted hereby under any patents, copyrights or other intellectual property rights of Renesas Electronics or others.
4. You shall not alter, modify, copy, or reverse engineer any Renesas Electronics product, whether in whole or in part. Renesas Electronics disclaims any and all liability for any losses or damages incurred by you or third parties arising from such alteration, modification, copying or reverse engineering.
5. Renesas Electronics products are classified according to the following two quality grades: "Standard" and "High Quality". The intended applications for each Renesas Electronics product depends on the product's quality grade, as indicated below.
 - "Standard": Computers; office equipment; communications equipment; test and measurement equipment; audio and visual equipment; home electronic appliances; machine tools; personal electronic equipment; industrial robots; etc.
 - "High Quality": Transportation equipment (automobiles, trains, ships, etc.); traffic control (traffic lights); large-scale communication equipment; key financial terminal systems; safety control equipment; etc.Unless expressly designated as a high reliability product or a product for harsh environments in a Renesas Electronics data sheet or other Renesas Electronics document, Renesas Electronics products are not intended or authorized for use in products or systems that may pose a direct threat to human life or bodily injury (artificial life support devices or systems; surgical implantations; etc.), or may cause serious property damage (space system; undersea repeaters; nuclear power control systems; aircraft control systems; key plant systems; military equipment; etc.). Renesas Electronics disclaims any and all liability for any damages or losses incurred by you or any third parties arising from the use of any Renesas Electronics product that is inconsistent with any Renesas Electronics data sheet, user's manual or other Renesas Electronics document.
6. When using Renesas Electronics products, refer to the latest product information (data sheets, user's manuals, application notes, "General Notes for Handling and Using Semiconductor Devices" in the reliability handbook, etc.), and ensure that usage conditions are within the ranges specified by Renesas Electronics with respect to maximum ratings, operating power supply voltage range, heat dissipation characteristics, installation, etc. Renesas Electronics disclaims any and all liability for any malfunctions, failure or accident arising out of the use of Renesas Electronics products outside of such specified ranges.
7. Although Renesas Electronics endeavors to improve the quality and reliability of Renesas Electronics products, semiconductor products have specific characteristics, such as the occurrence of failure at a certain rate and malfunctions under certain use conditions. Unless designated as a high reliability product or a product for harsh environments in a Renesas Electronics data sheet or other Renesas Electronics document, Renesas Electronics products are not subject to radiation resistance design. You are responsible for implementing safety measures to guard against the possibility of bodily injury, injury or damage caused by fire, and/or danger to the public in the event of a failure or malfunction of Renesas Electronics products, such as safety design for hardware and software, including but not limited to redundancy, fire control and malfunction prevention, appropriate treatment for aging degradation or any other appropriate measures. Because the evaluation of microcomputer software alone is very difficult and impractical, you are responsible for evaluating the safety of the final products or systems manufactured by you.
8. Please contact a Renesas Electronics sales office for details as to environmental matters such as the environmental compatibility of each Renesas Electronics product. You are responsible for carefully and sufficiently investigating applicable laws and regulations that regulate the inclusion or use of controlled substances, including without limitation, the EU RoHS Directive, and using Renesas Electronics products in compliance with all these applicable laws and regulations. Renesas Electronics disclaims any and all liability for damages or losses occurring as a result of your noncompliance with applicable laws and regulations.
9. Renesas Electronics products and technologies shall not be used for or incorporated into any products or systems whose manufacture, use, or sale is prohibited under any applicable domestic or foreign laws or regulations. You shall comply with any applicable export control laws and regulations promulgated and administered by the governments of any countries asserting jurisdiction over the parties or transactions.
10. It is the responsibility of the buyer or distributor of Renesas Electronics products, or any other party who distributes, disposes of, or otherwise sells or transfers the product to a third party, to notify such third party in advance of the contents and conditions set forth in this document.
11. This document shall not be reprinted, reproduced or duplicated in any form, in whole or in part, without prior written consent of Renesas Electronics.
12. Please contact a Renesas Electronics sales office if you have any questions regarding the information contained in this document or Renesas Electronics products.

(Note1) "Renesas Electronics" as used in this document means Renesas Electronics Corporation and also includes its directly or indirectly controlled subsidiaries.

(Note2) "Renesas Electronics product(s)" means any product developed or manufactured by or for Renesas Electronics.

(Rev.4.0-1 November 2017)

Corporate Headquarters

TOYOSU FORESIA, 3-2-24 Toyosu,
Koto-ku, Tokyo 135-0061, Japan
www.renesas.com

Trademarks

Renesas and the Renesas logo are trademarks of Renesas Electronics Corporation. All trademarks and registered trademarks are the property of their respective owners.

Contact information

For further information on a product, technology, the most up-to-date version of a document, or your nearest sales office, please visit:
www.renesas.com/contact/.